

Engraving Machine K405 1 channel , Sprint 8kHz , refurbished



HELL Gravure Systems GmbH D - 24107 Kiel
 Type K406 ID - No. 05177404
 Ser. - No. 83612090
 400 V 50 Hz 30 A
 Date of Manufacture March 1998
 Made in Germany

Machine base: model 3055 length: 5000mm
 year of manufacture: circa 1980
 equipment carriage: model 3055 length: 1109 mm
 engraving mode : ring

electronic cabinet: K405
 year of manufacture: 1998

PC: Windows 2000 SP3, English
 HelioControl V

engraving head:
 one head is include and eligible: Sprint CF (screen 60-100)
 or Sprint BF (screen 54-80)

Basic

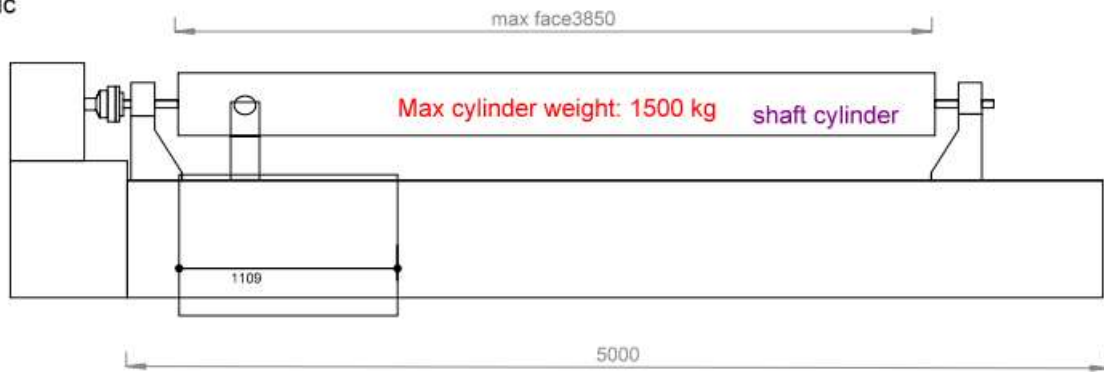

Options:

1) clamp hollow cylinder

- pneumatic end-tailstock inclusive turning cone and three-jaw chuck at gearbox side

Option

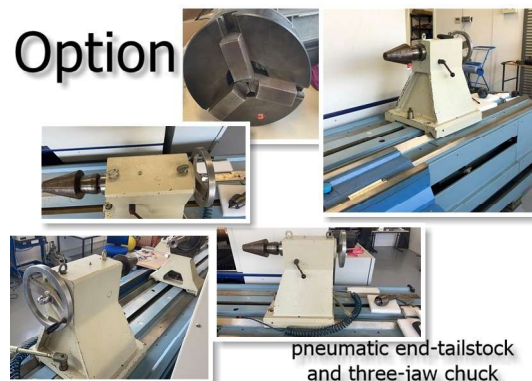

pneumatic end-tailstock and three-jaw chuck

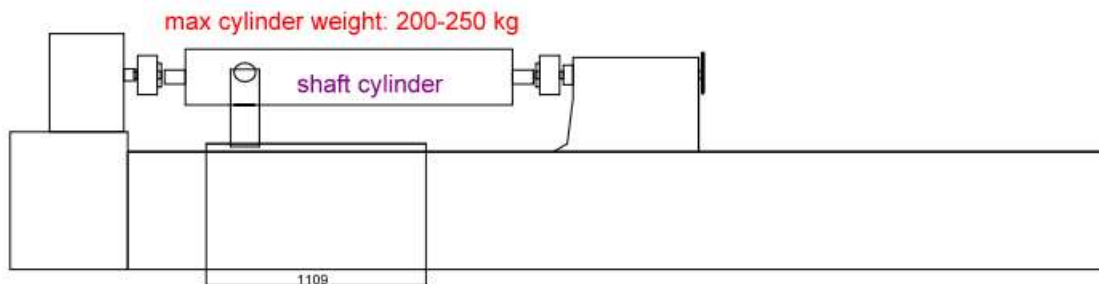
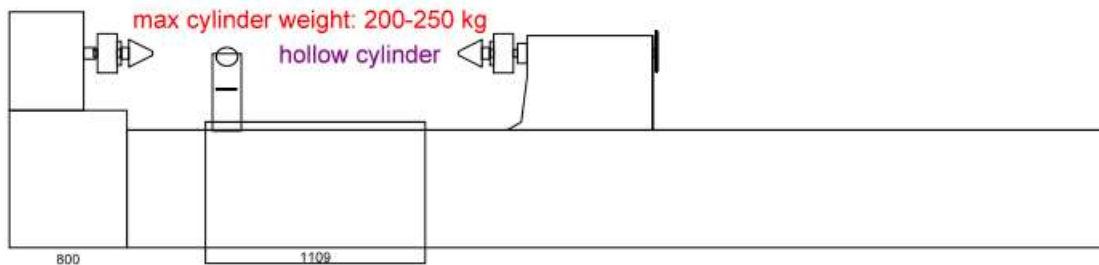

2) additional engraving heads

used refurbished engraving head or new engraving heads type: Sprint CF 60-100 ,

Sprint BF 54-80

Xtreme 22

Coarse Screen A 48-50

Option



engraving heads